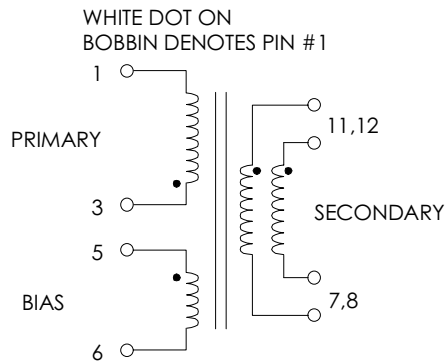

**TABLE 1: ELECTRICAL SPECIFICATIONS AT 25 °C**  
 SWITCHING TRANSFORMER DESIGNED FOR USE WITH POWER INTEGRATIONS  
 TOP226Y. REFER TO APPLICATION CIRCUITS OF FIGURE 3.

PARAMETER	SPEC LIMITS			UNITS
	MIN.	TYP.	MAX.	
PRIMARY INDUCTANCE (3-1) VOLTAGE = 0.250Vrms FREQUENCY = 100 KHZ	540	600	660	μHY
TURN RATIO'S: SEC (11,12-7,8) : PRIMARY (3-1) BIAS (5-6) : PRIMARY (3-1)	-----	1:4.625 1:7.333	-----	± 3% ± 3%
PRI LEAKAGE IND. (SEC SHORTED) VOLTAGE = 0.250Vrms FREQUENCY = 100 KHZ	-----	15.0	20.0	μHY
HIPOT TEST 50/60 HZ, 1 Minute Min. PRIMARY TO SECONDARY BIAS TO SECONDARY	3750 3750	----- -----	----- -----	Vrms Vrms
FIGURE 3A CIRCUIT PARAMETERS: (1) AC LINE VOLTAGE 47/400 Hz OUTPUT VOLTAGE OUTPUT CURRENT CONTINUOUS OUTPUT CURRENT PEAK LINE REGULATION (85 TO 265Vac) LOAD REGULATION 10-100% RIPPLE	85 ----- 0.0 ----- ----- ----- ----- -----	----- 24.0 ----- ----- 0.20 0.20 50.0	265 ----- 2.00 2.50 ----- ----- -----	Vac Vdc Amps Amps ±% ±% ±mV

(1) REFER TO APPLICATION CIRCUIT OF FIGURE 3.

**FIGURE 1: SCHEMATIC DIAGRAM**



SECONDARY PINS #12 & 11, #8 & 7 MUST BE RESPECTIVELY CONNECTED TOGETHER FOR PROPER OPERATION. I.E. CONNECTED AS ONE PARALLEL WINDING.

**NOTE1:**  
**REINFORCED INSULATION SYSTEM, UL 1950, IEC950, CSA-950:**  
 A) ALL MATERIALS MEET "UL", "CSA" & "IEC" REQUIREMENTS  
 B) TRIPLE BASIC INSULATED SECONDARY.  
 C) DESIGNED TO MEET ≥6.2mm CREEPAGE REQUIREMENTS.  
 D) VARNISH FINISHED ASSEMBLY.  
 E) UL 1950 & CSA-950 CERTIFIED: FILE #E162344.  
 F) UL CLASS (B) 130 INSULATION SYSTEM PM130-R1, PM130-H1, PM130-H1A (UL FILE #E177139) OR ANY UL AUTHORIZED CLASS (B) INSULATION SYSTEM.

**FIGURE 2: PHYSICAL DIMENSIONS mm (INCHES)**

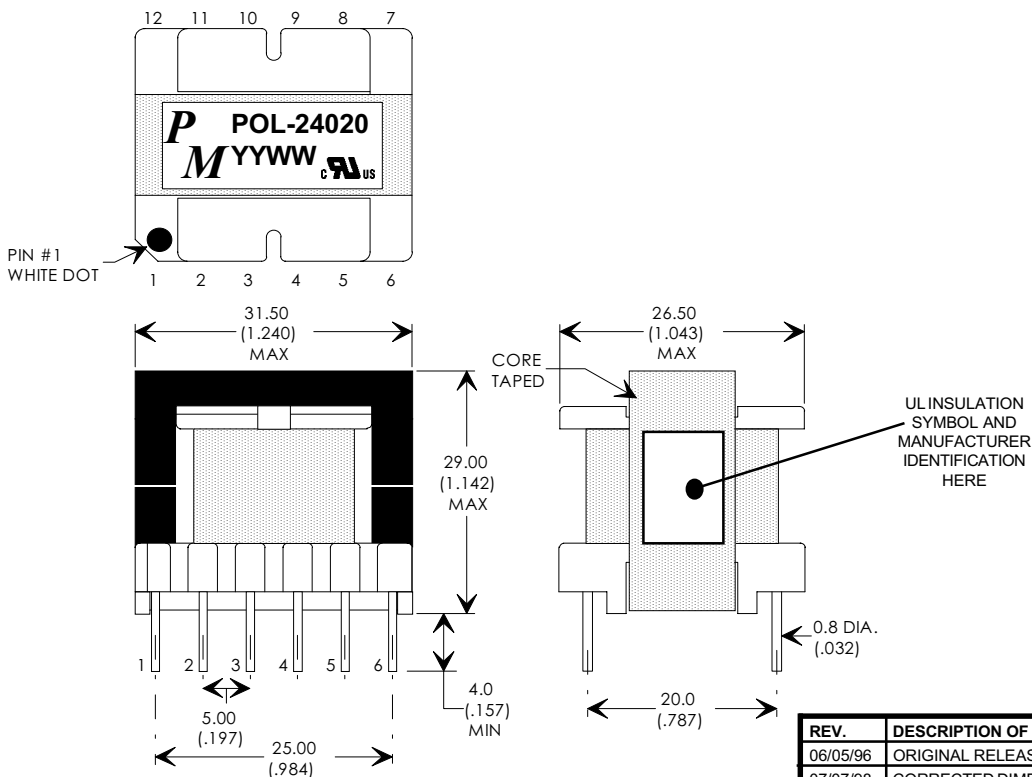

EE30 (FEE30A) -OR- EI30(FEI30), 12-PIN VERTICAL BOBBIN

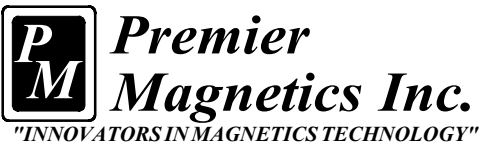

UNLESS OTHERWISE SPECIFIED  
 DIMENSIONS ARE IN MM  
 DIMENSIONAL TOLERANCES ARE:  
 DECIMALS ANGLES  
 .X ± .25 ±0° 30'  
 .XX ± .15  
 DO NOT SCALE DRAWING

REV.	DESCRIPTION OF CHANGES	BY
06/05/96	ORIGINAL RELEASE	TO
07/07/98	CORRECTED DIMENSIONS	TO
10/10/98	UPDATED TO ADD UL 1950 & CE-950 APPROVAL & MARKING	TO
11/18/98	UPDATE HIPOT FROM 3000 TO 3750 & ADDED TEST 1 MIN. MINIMUM	MD
05/10/99	UPDATE TO UL CLASS (B) 130 INSULATION SYSTEM	MD

**TRANSFORMER CONTROL DRAWING**

PREMIER P/N: POL-24020	REVISION: 05/10/99
DRAWN BY: TOM O'NEIL	REF: TOP226Y/204Y
SCALE: NONE	SHEET: 1 OF 6

## APPLICATION NOTES

Premier Magnetics' POL-24020 Switch Mode Transformer was designed for use with Power Integrations, Inc. TOP226Y three terminal off-line PWM switching regulator in the Flyback Buck-Boost circuit configuration. This conversion topology can provide isolated multiple outputs with efficiencies up to 90%. Premier's POL-24020 transformer has been optimized to provide maximum power throughput.

The TOPXXX series from Power Integrations, Inc. are self contained 100KHz three terminal voltage controlled PWM switching regulators. This series contains all necessary functions for an off-line switched mode control DC power source. These switching regulators provide a very simple solution to off-line designs. The inductors and transformer used with the TOPXXX are critical to the performance of the circuit. They define the overall efficiency, output power and overall physical size.

Below is a universal input high precision 50 watt application circuit utilizing Power Integrations TOP226Y switching regulator in the flyback buck-boost configuration. The component values listed are intended for reference purposes only. A properly sized heat sink for the PWR-TOP204 & D3 are required for efficient and reliable operation. Soft start capacitor C<sub>ss</sub> is optional and application dependent.

**FIGURE 3: TYPICAL APPLICATION CIRCUIT**

